

A Modern Directional Power/SWR Meter

*Every ham needs an RF power meter.
Here's a high performance unit to build at home.*

Bill Kaune, W7IEQ

I first got the idea of designing and building a power meter from a construction article in *The 1997 ARRL Handbook* entitled “The Tandem Match — An Accurate Directional Wattmeter” by John Grebenkemper, KI6WX. John described the difficulties of building an accurate power meter using diodes to convert RF to dc because of the diode’s inherent nonlinearity. He describes a fairly complicated (at least it looked complicated to me) analog circuit that corrects for this nonlinear behavior and that also calculates and displays SWR.

Shortly after reading this article, I noticed several articles in *QST* that described a new integrated circuit, the Analog Devices AD8307, that converts a low level RF signal into a voltage proportional to the logarithm of the signal’s power. I became intrigued with this device because it eliminated the difficulties associated with the use of diodes and would work over a wide range of powers, from milliwatts to the legal limit.

In addition, I was interested in learning more about microprocessors. Thus, I developed the idea of using AD8307s in the front end of a power meter to convert from RF watts to dBm, then a microprocessor with a built-in analog-to-digital converter (ADC) to process the dBm signals and display power and SWR on a liquid crystal display panel and, perhaps, a panel meter.

The primary use I had in mind for this unit was to monitor the output power and tuning of my rig. I live in an area with antenna restrictions so must operate with a wire antenna whose configuration is more determined by my lot size and configuration than by electrical considerations. Thus, my antenna does not present a good match to 50 Ω on any amateur band. As a consequence, I always use a manual antenna tuner. My setup, including the power meter described here, is shown in Figure 1.

RF power generated by my transmitter is routed via RG-8 coaxial cable through a directional coupler to my antenna tuner, which is connected to my antenna with about 60 additional feet of RG-8. The directional coupler contains circuits that sample the

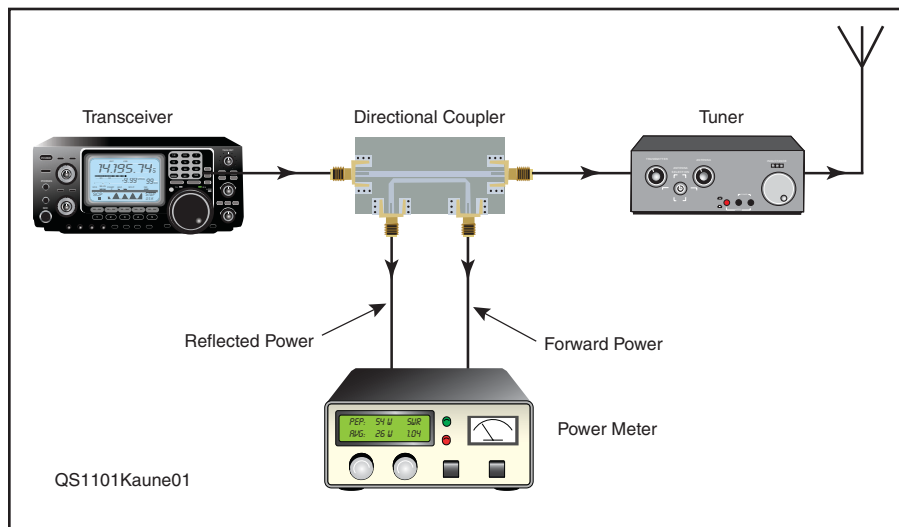

Figure 1 — W7IEQ station setup, including the power meter being described here.

RF power flowing from the transmitter to the tuner (the *forward power*) and the RF power reflected back from the tuner to the transmitter (the *reflected power*). These samples are sent via RG-58 cable to the two input channels of the power meter. This article describes the directional coupler and the power meter in enough detail so that an interested ham can duplicate the device or, perhaps, improve on my design.

Directional Coupler

The directional coupler I built is based on the unit described in the article by John Grebenkemper mentioned earlier. Coaxial (SO-239) UHF sockets were mounted on opposite faces of an aluminum box (Radio Shack 270-238). A cable from the transceiver was connected to one of these sockets and the other was connected to my antenna tuner. Two BNC sockets were mounted 2 inches away from these coax sockets. Two short lengths of RG-8 coaxial cable were prepared by exposing about 1/4 inch of the shield on one end of each. I wound 31 turns of #26 AWG magnet wire on each of two Amidon FT-82-67 ferrite toroids so that the windings occupied about 75% of the circumferences of the cores. These toroids were then slipped

over the two sections of RG-8 until they were about 1/2 inch from the end of the exposed shield. One section of RG-8 was soldered between the two UHF sockets and the other between the two BNC sockets. Holes were drilled in the PC board shields to accommodate these two lengths of cable.

The exposed braid at one end of each section of RG-8 was soldered to a nearby solder lug, as shown in Figure 2. (Do not solder the other end of the braid to ground.) This braid forms a shield that prevents capacitive coupling between the transmission line and the wire wound on the toroids. In addition, one lead from each of the toroids was soldered to these lugs. The other lead from each toroid was passed through the center shield and soldered to the center terminal of the nearby connector. Small rubber grommets were used to insulate the points that these leads passed through the center shields.

The forward and reflected power samples coupled from the main line are reduced by a factor of $1/N^2$, where $N = 31$ is the number of turns of wire on each toroid. Thus the forward and reflected power samples are reduced by about 30 dB. For example, if a transceiver were delivering a power of 100 W to a pure 50 Ω load, the forward power sample from

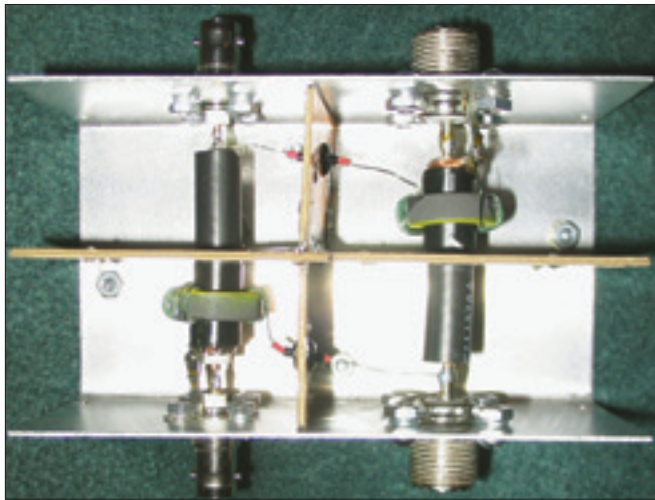

Figure 2 — Completed directional coupler.

the directional coupler would be about 0.1 W (20 dBm) and the reflected power sample, in theory at least, would be exactly 0 because there would be no reflections from the 50 Ω load. Of course, in a real device, the reflected power sample will never be exactly 0. The *directivity* of a directional coupler is defined as the ratio of the forward power sample divided by the reflected power sample when the coupler is terminated in 50 Ω . In my coupler, the directivity, measured using an inexpensive network analyzer, is at least 35 dB at 3.5 MHz and 28 dB at 30 MHz.

Power/SWR Meter — Circuit Description

Figure 3 shows a front panel view of the power meter. I used a two line, 20 characters per line, liquid crystal display (LCD) to display the measured peak (PEP) and average (AEP) envelope powers as well as the standing wave ratio (SWR). Depending on the position of a front panel switch, the power meter calculates either the peak and average envelope power traveling from the transceiver to load (the forward power) or the peak and average envelope powers actually delivered to the load (the forward power minus reflected power). The average envelope power (AEP) represents an average of the forward or load powers over an averaging period, depending on the position of a second front-panel switch, of either 1.6 or 4.8 seconds. I generally use the shorter period, but sometimes use the longer when I am operating SSB.

I included a 1 mA-movement analog meter on the front panel to facilitate antenna tuning. This meter continuously displays the quantity $1 - 1/SWR$, where SWR is the standing wave ratio on the line. Thus, an SWR of 1.0 corresponds to a meter reading of 0, that is no deflection of the meter. An SWR of 2 results in a 50% deflection of the

meter, while an SWR of 5 produces an 80% deflection of the meter. I have found this method of displaying SWR to be effective for antenna tuning.

Figure 4 shows the schematic diagram and parts list of the power meter. The forward and reflected power samples from the directional coupler enter at the left through two identical channels. Since the logarithmic detectors, U1 and U2 in Figure 4, can only handle a maximum input power of about 15 dBm, I placed two external 20 dB attenuators (Mini-Circuits HAT-20) in cables from the directional coupler. As noted earlier, the directional coupler has an internal attenuation of about 30 dB, so the total attenuation in each channel is about 50 dB. Thus, a rig operating at a power level of 1 kW (60 dBm) will result in an input to the forward power channel of about 10 dBm.

The internal input impedances of the logarithmic detector chips, U1 and U2, are about 1100 Ω in parallel with 1.4 pF. These impedances are in parallel with R1 and R2, respectively, both 52.3 Ω , yielding net input impedances of 49.9 Ω . Capacitors C7 and C8 set the time constants of the output networks of U1 and U2 to filter out RF components in the signal while retaining the modulation components with frequencies up to about 20 kHz. In other words, the outputs of U1 and U2 follow the modulation envelope of the RF signal.

The output signals from U1 and U2 enter U3 and U4, sample-and-hold (S/H) integrated circuits. These circuits operate as follows: As long as the voltages on pins 8 are held high (+5.0 V), the outputs on pins 5 are the same as the inputs (pins 3). However, if the voltages on pins 8 are set low (≈ 0 V), the outputs become *frozen* at the values at the inputs at the moment when the voltages on pins 8 were changed. In this way, input voltages from the forward and reflected power



Figure 3 — Front panel of power meter. The LCD shows the peak envelope power (PEP), the average envelope power (AEP) and the SWR. The two knobs control the contrast and back lighting of the LCD. One toggle switch determines whether forward or load powers are displayed. A second switch sets the averaging time for the AEP calculation. The meter shows the SWR and is used for tuning purposes.

logarithmic detectors can be sampled at the exact same time and held for subsequent serial reading into the microprocessor.

I used a PIC microprocessor in the power meter for several reasons. PIC processors seem to be used in a many types of amateur equipment, so it seemed sensible to become familiar with them. They are remarkably inexpensive. Being RISC (reduced instruction set computers), they have a relatively small number of instructions to learn. Also, you can purchase units that contain a variety of on-chip peripherals, such as analog-to-digital converters (ADC). And, finally, there are software and a large number of helpful documents available for no charge from the producer of these devices (www.microchip.com).

Because I needed a device with at least two channels of ADC and a way of outputting a voltage that would drive an analog panel meter, I selected the PIC16F876A, which includes five input analog channels and a pulsewidth modulated output. The two analog signals from the S/H chips were input on pins 2 and 3 of U5, the system processor. In this processor, the ADC is a 10 bit device and conversion can be done relative to a reference voltage. While you can use the 5.0 V supply voltage for this purpose, I elected to improve the accuracy and stability of the unit by using a separate voltage reference chip (U7) that delivers a precise 2.50 V from its pin 6. This choice was also appropriate because the maximum output voltage from the logarithmic converters is close to 2.5 V.

I operated the processor with a 20 MHz clock, which corresponds internally to an instruction execution time of 200 ns (four clock cycles per one instruction cycle). As noted earlier I selected a two line, 20 character per line, LCD to display digital values of the peak envelope power (PEP), average envelope power (AEP), and SWR. R4 adjusts the contrast of the display and R8 its

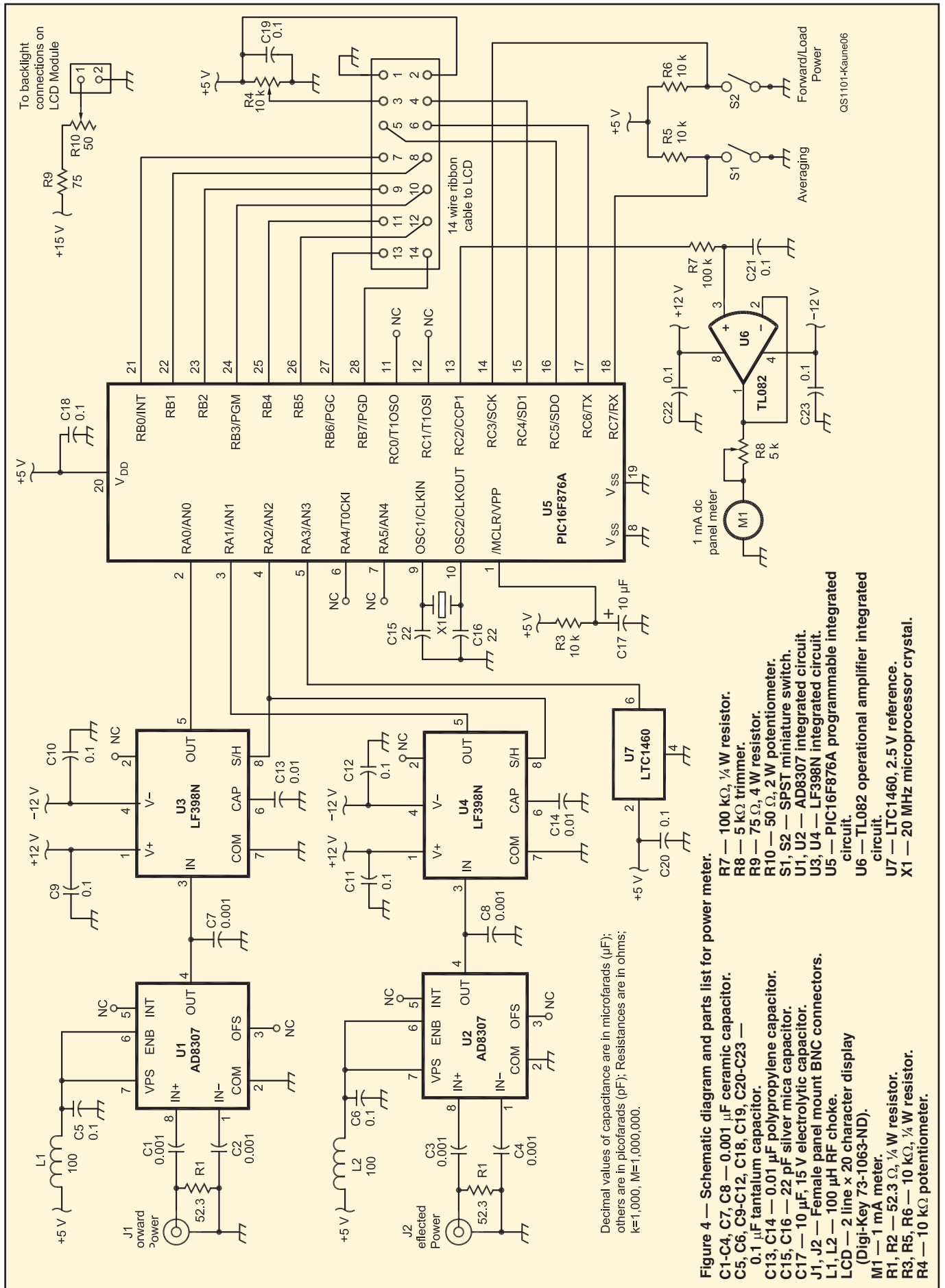

Figure 4 — Schematic diagram and parts list for power meter.
C1-C4, C7, C8 — 0.001 μ F ceramic capacitor.
C5, C6, C9-C12, C18, C19, C20-C23 — 0.1 μ F tantalum capacitor.
C13, C14 — 0.01 μ F polypropylene capacitor.
C15, C16 — 22 pF silver mica capacitor.
C17 — 10 μ F, 15 V electrolytic capacitor.
J1, J2 — Female panel mount BNC connectors.
LCD — 2 line x 20 character display (Digi-Key 73-1063-ND).
M1 — 1 mA meter.
R1, R2 — 52.3 Ω , 1/4 W resistor.
R3, R5, R6 — 10 k Ω , 1/4 W resistor.
R4 — 10 k Ω potentiometer.
R7 — 100 k Ω , 1/4 W resistor.
R8 — 5 k Ω trimmer.
R9 — 75 Ω , 4 W resistor.
R10 — 50 Ω , 2 W potentiometer.
S1, S2 — SPST miniature switch.
U1, U2 — AD8307 integrated circuit.
U3, U4 — LF398N integrated circuit.
U5 — PIC16F876A programmable integrated circuit.
U6 — TL082 operational amplifier integrated circuit.
U7 — LTC1460, 2.5 V reference.
X1 — 20 MHz microprocessor crystal.

Decimal values of capacitance are in microfarads (μ F); others are in picofarads (pF); Resistances are in ohms; k=1,000, M=1,000,000.

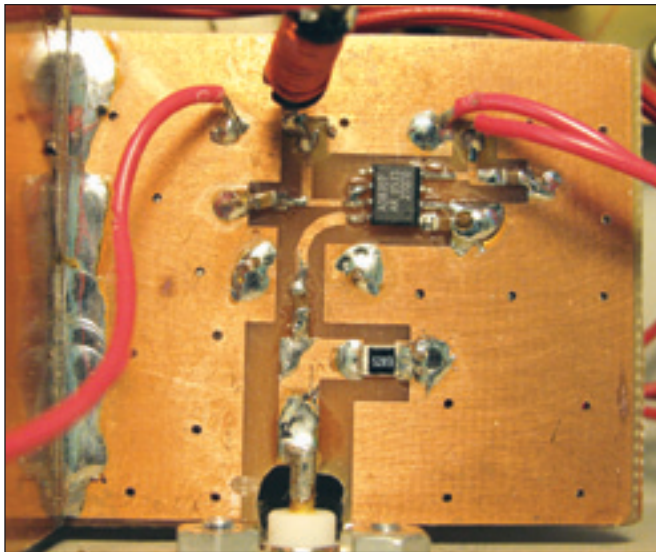

Figure 5 — One of the two RF logarithmic converters.

brightness. In practice, I never change these settings, so if I were building this unit again, I would place them on the back panel.

The PIC processor includes a pulsewidth-modulated output that I use to control the analog SWR meter on the front panel. Essentially, this peripheral produces an output train of rectangular pulses with a frequency of about 4.9 kHz. The pulse height is 5.0 V, the operating voltage of the processor. The spacing in time between two consecutive pulses is about 200 μ s. In software, the width of the pulses can be adjusted in 256 increments from 0 μ s (the output voltage is always 0) to 100 μ s (output is 50% high and 50% low) to 200 μ s (output is always high). R7 and C21 comprise a low-pass filter that removes the 4.9 kHz component and leaves only the dc component of this pulse train. In other words, this filter essentially “calculates” the average voltage from the pulsewidth modulated stream, which ranges from 0 V when the pulsewidth is 0 μ s to 5.0 V when it is 200 μ s.

Construction Notes

The power meter was built in a 8 \times 3 \times 6 inch deep aluminum cabinet purchased from our local RadioShack; unfortunately this cabinet is no longer available. The RF circuits associated with U1 and U2 were constructed on a small piece of PC board. Figure 5 is a close-up photograph of one of these circuits. I actually built two versions. The first used the *dead bug* construction method and included about 20 dB of on-board attenuation. Unfortunately, the result was somewhat frequency sensitive. The second version used surface mount parts and did not include any internal attenuation.

Eight data lines and three control lines connect between the microprocessor and

the LCD. These connections, as well as the connections associated with power, ground and the contrast circuits for the display, were accomplished using a 16 wire ribbon cable. This cable can be seen in Figure 6.

The following components were mounted on the front panel: The brightness and contrast potentiometers (R9 and R4, respectively), the FORWARD/LOAD POWER and AVERAGING TIME switches (S1 and S2, respectively), the LCD display and the SWR analog meter (M1). Connections between these components and the main PC board were made using Molex connectors. I purchased a number of 12 pin male and female headers (Digi-Key WM4010-ND and WM2021-ND) and associated crimp terminals (WM2200-ND). I then cut the headers into smaller pieces (fewer pins) as needed, and soldered the terminals onto the wires in each cable harness. As Figure 6 shows, I used these connectors liberally so that the PC board could be removed without having to unsolder any connections. Finally, I mounted a male DB-9 connector on the rear panel for connection to the remote power supply.

Power Supply

The power supply needs to supply the following voltages: an unregulated 15 V for the back-lighting of the LCD display; a regulated \pm 12 V for the sample and hold chips (U3 and U4) and U6, the meter driver; and a regulated +5.0 V for the RF deck, system microprocessor and the voltage reference chip (U7). Since the power requirements are small, I constructed a simple power supply using only a single transformer. The schematic and parts list are given in Figure 7. I built the power supply in a separate aluminum box (RadioShack 170-238) and all the parts for it were obtained from Radio Shack. I used a

9 pin serial cable from my junk box to carry power from this supply to the power meter.

Software

As in many modern pieces of electronic equipment, a microprocessor plays a key role in my power meter. As noted earlier, I selected the PIC16F876A for my power meter. While I found the PIC relatively easy to program, learning how to use the various peripherals was more of a challenge. The data sheets from the manufacturer were difficult to follow, and I only began to make progress after purchasing a third-party book describing these units.¹

When power is supplied to the power meter, the microprocessor will not start until the voltage at pin 1 rises to a threshold value. R3 and C17 establish a time constant of 0.1 seconds, enforcing a delay of about ¼ second. This allows the supply voltages time to stabilize before the processor starts. Once running, the processor samples the forward and reflected power signals every 90 μ s, that is, at a rate of 11.1 kHz. Between each sample, the processor converts the power signals, in dBm, to watts. Each measured dBm value is a 10 bit number. This number is used as an index into lookup tables held in program memory. After lookup, each forward and reflected power becomes a 16 bit floating-point number in units of watts. Each forward power value is added to an accumulator, later used to calculate the average envelope power (AEP). In addition, the processor keeps track of the maximum forward power and the respective reflected power.

After 1111 samples, taken during a period of 0.10 seconds, the processor pauses to calculate the SWR, using the maximum forward and corresponding reflected powers measured during this period, updates the front panel tuning indicator, and updates the LCD display if the maximum forward power measured during the period exceeds the PEP value being displayed at that moment. Depending on the setting of the front-panel averaging switch, either 16 or 48 cycles of 1111 samples each are taken, at which point a new value of the AEP and SWR are calculated and displayed on the LCD.

The lookup tables for the forward and reflected powers occupy 4098 bytes (50%) of the available program memory. The remainder of the program uses 2753 bytes, of which 885 bytes are consumed by a 24

¹M. Predko, *Programming and Customizing PIC Microcontrollers*. McGraw-Hill, New York (2001). Available from Amazon (www.amazon.com) or Barnes & Noble (www.barnesandnoble.com).

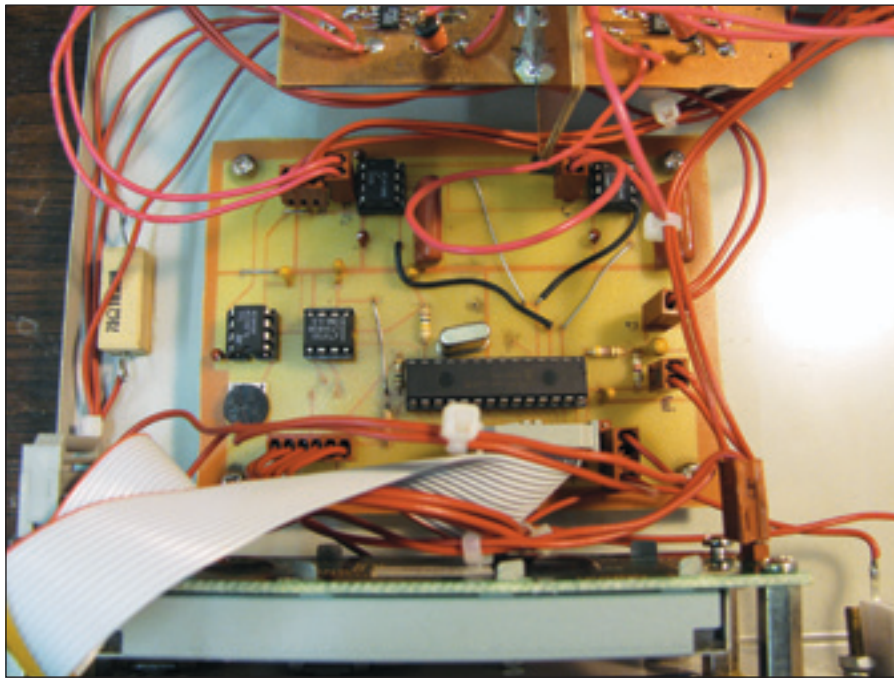

Figure 6 — Interior of power meter. The front panel of the unit is below the bottom of the photograph. The edge of the RF board shows at the top of the photograph. The larger integrated circuit in the middle of the photograph is the 16F876A processor. The two sample-and-hold integrated circuits are located above the processor. The two chips to the left of the processor are a 2.50 V precision voltage reference and a TL082 operational amplifier.

and reflected power channels as I inputted various power levels to each channel. In this way, I determined that $\alpha = 0.10063$ and $\beta = -70.83$ for the forward power channel and $\alpha = 0.09965$ and $\beta = -71.50$ for the reflected power channel. Unfortunately, I have no way to accurately measure absolute power, so these values are somewhat uncertain by perhaps $\pm 10\%$ or so.

Once I had determined the calibrations of the two channels, I constructed the look-up tables used by the processor to quickly determine the power in watts corresponding to a measured ADC number.

Conclusions

In contrast to a number of my projects, the power meter described here seems to work well and has proved to be a useful instrument. I use it whenever I operate. My transceiver has a maximum output of a little more than 200 W, and I have a linear amplifier that can run an output power of 1000 W. The power meter works well with both levels of power. What I did not anticipate when I built it is how well it works at low power levels. When I transmit SSB, but am not speaking into the microphone, the background noise in my shack is sufficient to produce an output power of about 0.1 W or so. I find that this power level is sufficient for me to adjust my antenna tuner using the tuning meter on the front panel of the power meter. In this way, I can tune up without disturbing other stations operating on nearby frequencies.

A version of this article with additional construction details, a discussion of how the coupler works and related Hamspeak items is provided on the QST-In-Depth Web site (www.arrl.org/qst-in-depth). Also there are the required firmware and PC board artwork.

Bill Kaune, W7IEQ, was first licensed in 1956 as a Novice and was licensed again in 1998. He upgraded to Amateur Extra class in 2000. Bill earned BS and PhD degrees in physics. He spent most of his career collaborating with biologists and epidemiologists researching the biological effects of power-frequency electric and magnetic fields. He is now retired.

Bill is married, has two grown daughters, four grandchildren and a standard poodle. In addition to Amateur Radio, he spends his time hiking and backpacking, including two recent trips to Alaska. Bill is currently the treasurer of the Jefferson County Amateur Radio Club, a member of the ARRL and a member of the ARRL's RF Safety Committee. You can reach him at 160 Cedarview Dr, Port Townsend, WA 98368 or at w7ieq@arrrl.net.

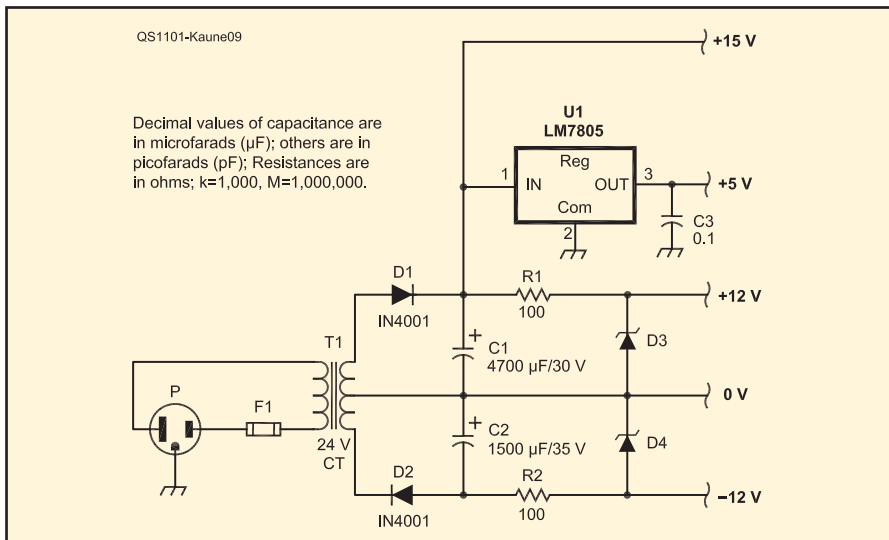

Figure 7 — Schematic diagram and parts list of the power supply.

C1 — 4700 μF , 35 V electrolytic capacitor.

C2 — 1000 μF , 35 V electrolytic capacitor.

D1, D2 — 1N4001 diode.

D3, D4 — 1N4742A 12 V Zener diode.

F1 — Fuse, 1A.

R1, R2 — 100 Ω , 1 W resistor.

T1 — Power transformer, 24 V CT.

U1 — LM7805 voltage regulator.

bit floating point package that I downloaded from the Microchip Web site.

Calibration

The output of a logarithmic converter is a voltage linearly proportional to the input RF power measured in units of dBm. Furthermore, the digitized value, D_{ADC} , of

the voltage measured by the ADC is a linear function of the input voltage. Putting these together, $\text{dBm} = \alpha D_{\text{ADC}} + \beta$, where α and β are constant. Calibration consists of determining these two constants. I did this by writing a special calibration program for the PIC processor that constantly displayed the digitized ADC values for both the forward

